

PLUS ALKALINE BATTERY

Document Title: PB032320

LR6

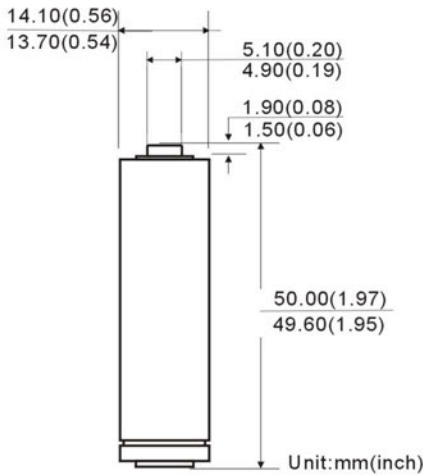

Chemical System : Alkaline

Zinc-Manganese Dioxide (Zn/MnO₂)

Camelion Model : LR6

IEC No. : LR6

ANSI/NEDA No. : 15A (AA)

Average Weight : 24.0g

Dimension (∅ x H) : 14.1^{±0.2} x 49.8^{±0.3} mm
0.56^{±0.01} x 1.96^{±0.01} inch

Terminals : Flat

Nominal Voltage : 1.5Volts

Average Capacity : 2800 mAh to 0.8 volts
(20 ± 2°C, Rated capacity at 25 mA continuous drain)

Jacket : Aluminum Foil Label

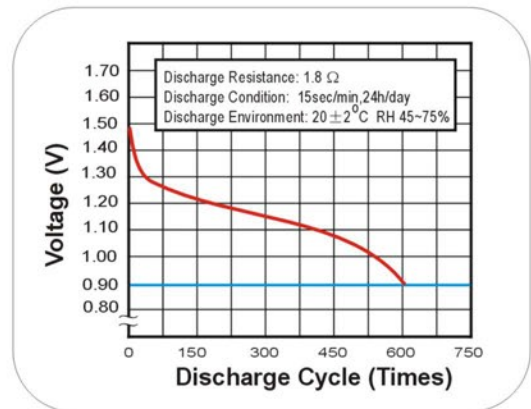
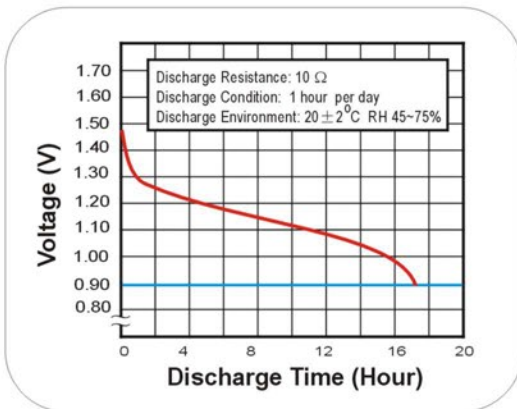
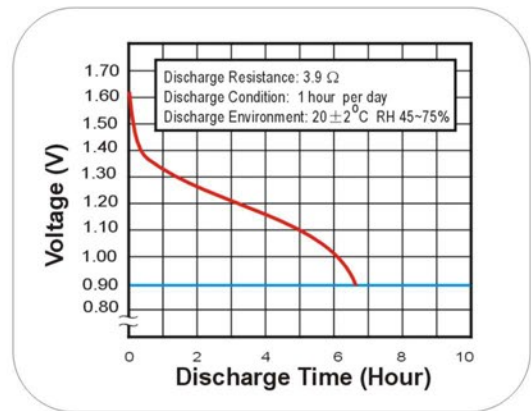
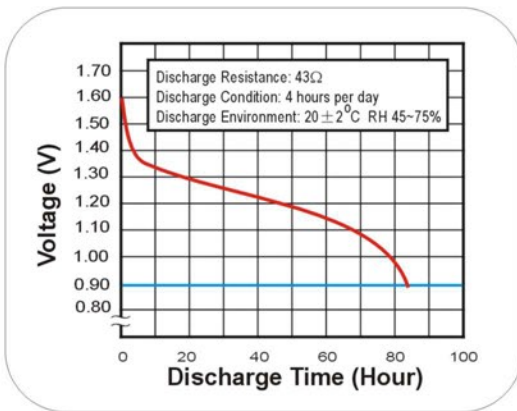

Notice:

Environmental elements comply with RoHS requirements. This information is subject to change without prior notice and for reference only. It should not be used as a basis for a product guarantee or warranty. For additional information, please consult your nearest Camelion Sales Office or Distributor or visit our website at: www.camelionbattery.com.